

Installation and Operation Manual TSCHAN®
Torsionally Rigid Coupling

POSIFLEX® **ZEA-BS / BT**
ZEB-BS / BT

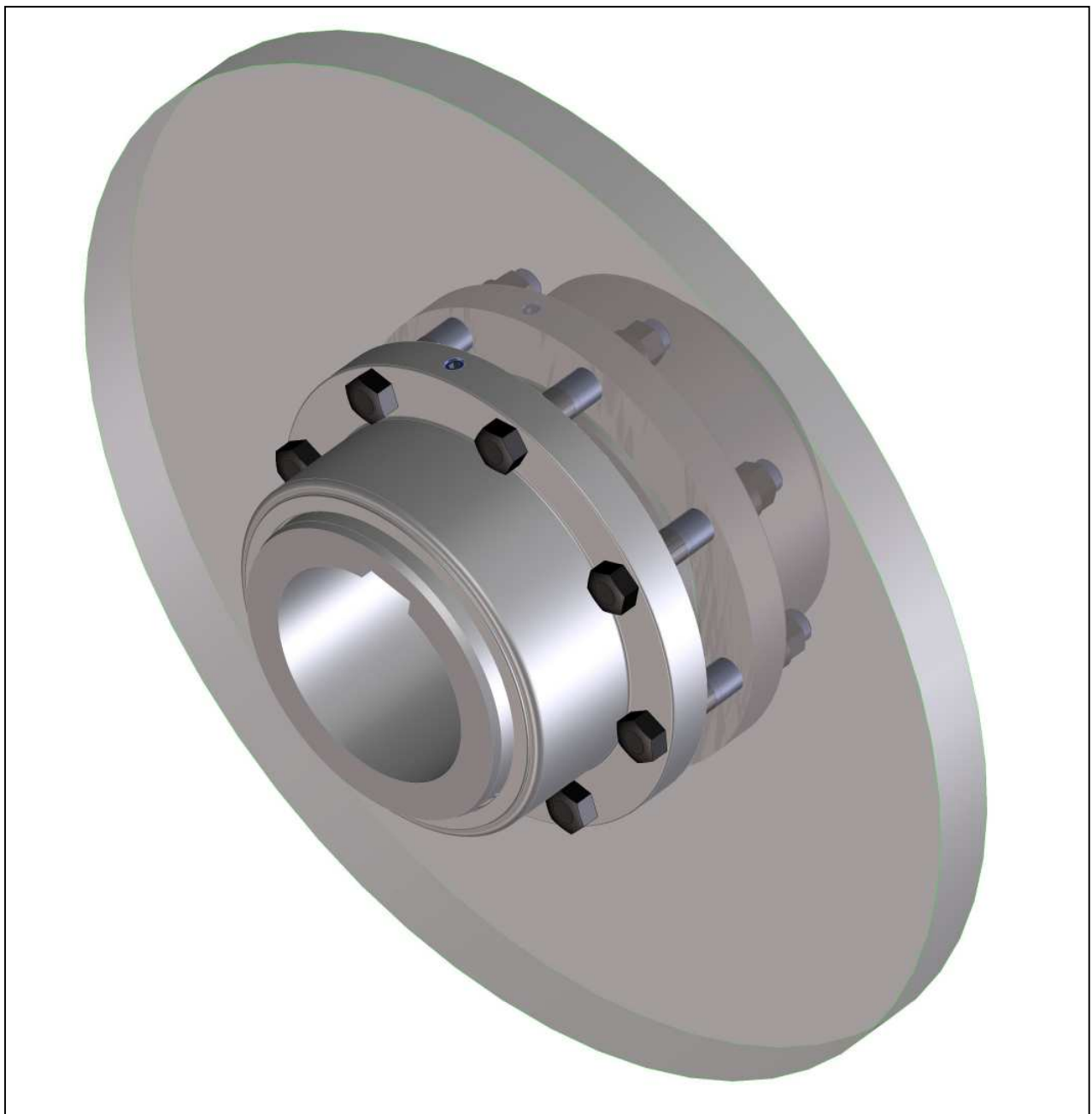

Inhalt

Kapitel	Seite
1 Safety Instructions	2
2 Function.....	3
2.1 Intended Application.....	3
3 Storage.....	4
4 Construction	5
5 Technical Data.....	6
6 Installation	9
6.1 To be observed prior to Installation	9
6.2 Finish bore in a hub	10
6.3 Coupling Installation	11
7 Coupling Alignment.....	14
7.1 Axial Misalignment ΔK_a	14
7.2 Angular Misalignment ΔK_w	15
7.3 Radial Misalignment ΔK_r	15
8 Operation.....	16
9 Maintenance	20
9.1 Inspection and Maintenance.....	20
9.2 Lubrication.....	21
10 Disposal.....	22

This Installation and Operation Manual is applicable to the coupling type POSIFLEX® ZEAU(U)-BS/BT, ZEAU(U)K-BS/BT, ZEBU(U)-BS/BT, ZEBU(U)K-BS/BT

1 Safety Instructions

This installation and operation manual is an essential component of the coupling delivery. Always keep this manual in a readily accessible place near the coupling. The German version of this AOI is leading and binding.

Take care that all persons being charged with the installation, operation, maintenance and repair of the coupling have read and understood this manual and that all instructions contained therein are carefully observed in order to:

- avoid danger to life and limb of the user or third persons,
- ensure the operational safety of the coupling,
- preclude operation failures and environmental damages due to wrong handling and misuse.

Except for the production of a finish-bore with keyway (see 6.2 'Finish Bore'), no further modifications are allowed to be performed to the coupling without the prior written approval by TSCHAN GmbH.

The relevant instructions and regulations regarding safety at work and environmental protection have to be observed while transporting, mounting and dismantling the coupling.

Make sure that suitable handling and transportation means are at disposal.

The coupling shall be operated, mounted, maintained and repaired by authorized, trained and instructed personnel only.

The user must take into account that the bolting elements of coupling parts may be adversely affected by the heat produced by a brake disk/ brake drum due to the resultant friction. Make sure that the combination of the employed brake lining with the material of the brake disk/ brake drum does not lead to sparks or impermissible thermal growth. The brake disk is normally made of steel, and the brake drum is normally made of cast iron with nodular graphite. In case of any doubt, please consult the supplier!

In the interest of further development, we reserve the right to carry out modifications serving the technical progress.

We do not assume any liability or warranty for any damages resulting from the use of accessories and parts that are not originally manufactured by TSCHAN GmbH.

2 Function

The TSCHAN[®] POSIFLEX[®]-coupling is a torsionally stiff gear coupling with a certain backlash. It compensates for angular, parallel and axial shaft misalignments within defined ranges. Parallel shaft offset can only be compensated by the double engagement design with two toothing planes. The coupling transmits the torque via hubs with crowned gear teeth which are in permanent mesh with the straight gear teeth of the sleeves. There must be a certain gear tooth circumferential clearance in order to compensate misalignments of the connected machines.

The coupling is suitable for horizontal installation in each direction of rotation. For applications involving other than horizontal position, it may be necessary to support the housing or the spacer. Please contact TSCHAN GmbH, if this has not been taken into account when selecting the coupling size.

It is imperative to use a lubricant that is appropriate for the specific requirements of the gear coupling in order to ensure reliable and continuous operation. Avoid pollution by leaking lubricant.

2.1 Intended Application

- The coupling shall only be used in normal industrial air. Aggressive media can corrode coupling parts as bolts and sealings and are dangerous for the reliability of the coupling. Consult TSCHAN GmbH in these cases.
- In order to ensure trouble-free and reliable performance of the coupling, the coupling has to be designed e.g. according to the selection specifications in the TSCHAN catalogue POSIFLEX[®] using a service factor that is appropriate to the operation conditions. See catalog 'Coupling Size Selection'.
- The values for max. torque, max. speed and max. misalignment as stated in the catalog dimension sheets must not occur simultaneously. See catalog 'Coupling Size Selection'.
- The POSIFLEX[®] Coupling with brake drum or brake disk in this design should only be used for a holding brake.
- The coupling shall only be used and operated within the frame of the conditions as defined in the performance or delivery contract.
- Any change in the operation conditions or service parameters requires the verification of the coupling design.

3 Storage

On receipt of the goods, immediately check that all parts are on hand and have been delivered as ordered. Shipping damages and/or missing parts have to be reported to TSCHAN GmbH in writing.

The coupling parts can be stored as delivered in a dry place indoors at normal ambient temperatures for a period of 18 months. In closed rooms with a high air humidity, the coupling parts can be stored for 12 months, outside of closed rooms they can be stored under a cover for 9 months, and without a cover for 3 months. Storage for a longer period requires the application of a long-term preservation. (Please consult TSCHAN GmbH regarding this subject). The coupling parts must not be exposed to aggressive products, extreme temperatures or direct humidity. The seals must not be stored together with acids, caustic solutions or other caustic chemicals; they must not be exposed to ozonic media, direct sun light or intensive light sources with UV light. The place of storage should be dry and free from dust. The air humidity must not exceed 65% and condensation is not permissible.

4 Construction

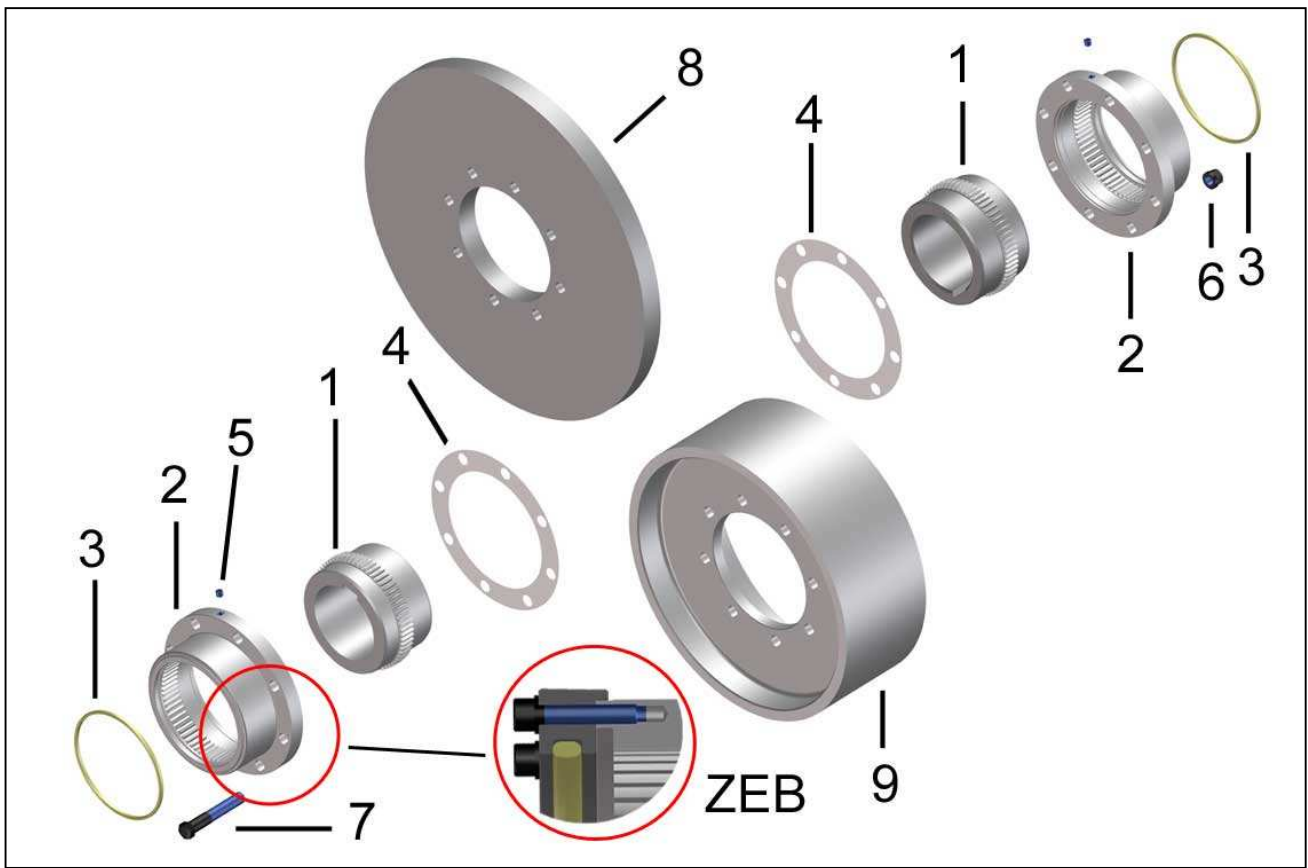

Fig. 1 Construction POSIFLEX® ZEA-BS / BT, ZEB-BS / BT

Item.	Description
1	Hub part 671 / part 672 U-hub, extended
2	Sleeve ZEA-design, part 670
3	O-ring, part 673
4	Flange seal, part 674
5	Screw plug
6	Hexagon nut, part 675
7	Fitted bolt, part 675
8	Brake disk part 505
9	Brake drum part 500

Important notes:

Balanced assemblies are match marked. Fitted bolts and nuts of balanced couplings are weight balanced. These sets must not be mixed with bolt sets of other couplings!

The couplings are not filled with grease when they are delivered.

5 Technical Data

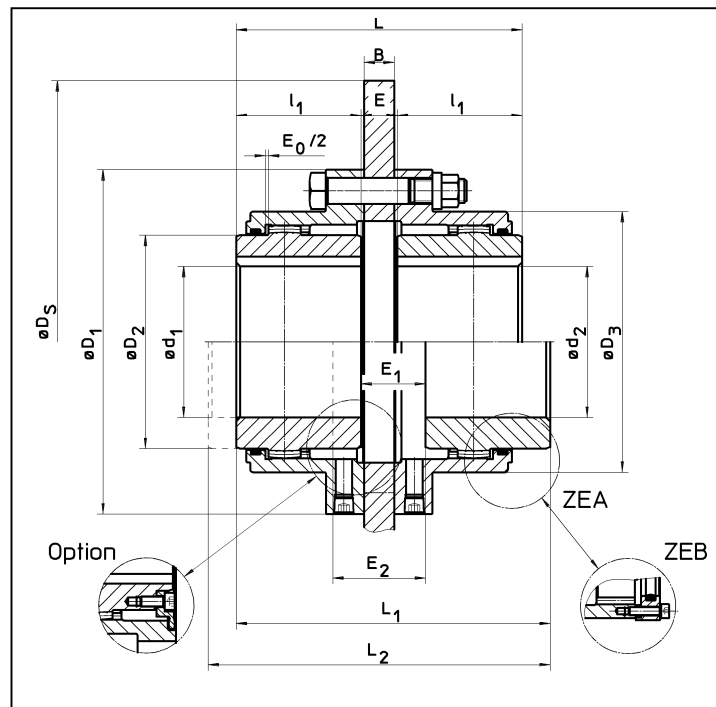

Fig. 2 POSIFLEX® ZEA-BS / ZEB-BS

Table 1 Technical Data ZEA-BS, ZEB-BS:

Size	T _{Cnom} [Nm]	T _{Cpeak} [Nm]	n _{max} [min ⁻¹]	d ₁ /d _{2max} [mm]	l ₁ [mm]	L [mm]	L ₁ [mm]	L ₂ [mm]	E ₀ [mm]	E [mm]	E ₁ [mm]	E ₂ [mm]
67	1300	2600	depending on brake disk	45	43	89+B	98+B	107+B	3	3+B	12+B	21+B
87	2800	5600		60	50	103+B	109+B	115+B	3	3+B	9+B	15+B
106	5000	10000		75	62	127+B	141+B	155+B	3	3+B	17+B	31+B
130	10000	20000		95	76	157+B	169+B	181+B	5	5+B	17+B	29+B
151	16000	32000		110	90	185+B	199+B	213+B	5	5+B	19+B	33+B
178	22000	44000		130	105	216+B	233+B	250+B	6	6+B	23+B	40+B
213	32000	64000		155	120	246+B	264+B	282+B	6	6+B	24+B	42+B
235	45000	90000		175	135	278+B	299+B	320+B	8	8+B	29+B	50+B
263	62000	124000		195	150	308+B	332+B	356+B	8	8+B	32+B	56+B

Size	D ₁ [mm]	D ₂ [mm]	D ₃ [mm]	D _s [mm]	B [mm]	m * without brake disk
67	111	67	80	300/315	12,7	4,1
87	141	87	103,5	350/355		8,0
106	171	106	129,5	400/515		14,6
130	210	130	156	450/610	15	26,1
151	234	151	181	515/710		38,1
178	274	178	209	610/810	30	59,2
213	312	213	247	610/810		89,4
235	337	235	273	610/810	42	117,5
263	380	263	307	610/810		167,1

* m [kg]: up to size 151 weight for unbored coupling, from size 178 on weight for pilot bored coupling.

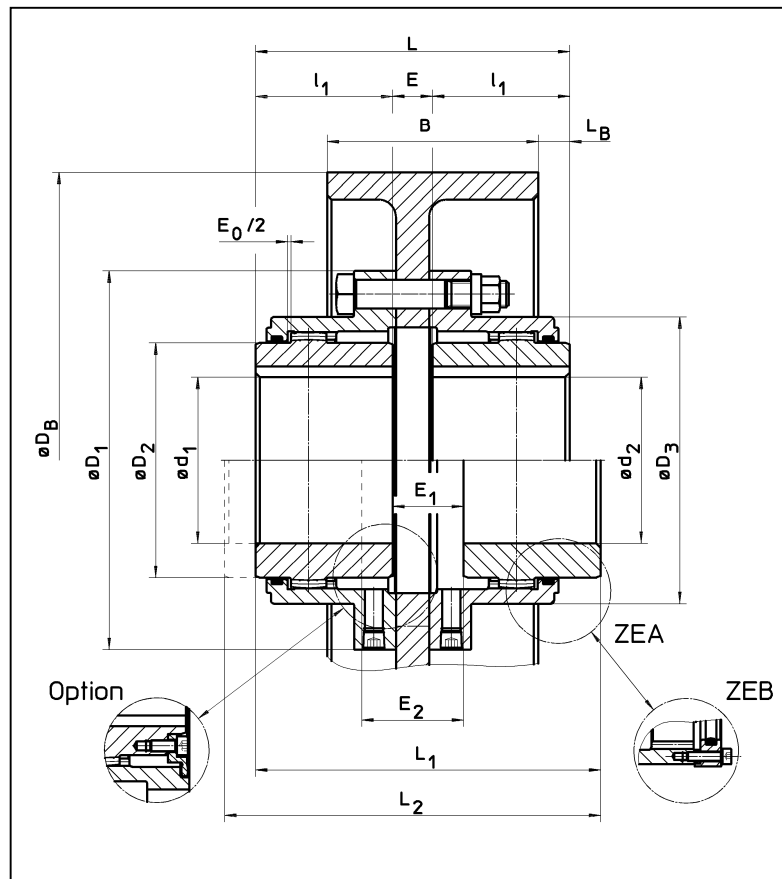

Fig. 3 POSIFLEX® ZEA-BT / ZEB-BT

Table 2 Technical Data ZEABT, ZEBBT:

Size	DB x B [mm]	T _{Cnom} [Nm]	T _{Cpeak} [Nm]	n _{max} [min ⁻¹]	d ₁ /d _{2max} [mm]	l ₁ [mm]	L [mm]	L ₁ [mm]	L ₂ [mm]	L _B ¹⁾ [mm]
67	200x75	1300	2600	2850	45	43	100	109	118	-1,0
87	200x75	2800	5600	2850	60	50	114	120	126	6,0
	250x95			116			122	128	-5,0	
	315x118			118			124	130	-14,0	
106	250x95	5000	10000	2300	75	62	140	154	168	7,0
	315x118			142			156	170	-6,0	
	400x150			144			158	172	-26,5	
130	315x118	10000	20000	1820	95	76	172	184	196	13,0
	400x150			1450			174	186	198	-11,5
151	315x118	16000	32000	1820	110	90	200	214	228	27,0
	400x150			1450			202	216	230	25,0
178	400x150	22000	44000	1450	130	105	233	250	267	18,0
	500x190			1150			234	251	268	-13,5
213	400x150	32000	64000	1450	155	120	263	281	299	33,0
	500x190			1150			264	282	300	1,5
	630x236			910			269	287	305	-18,5
	500x190			1150			296	317	338	17,5
235	630x236	45000	90000	910	175	135	301	322	343	-2,5
	710x265			800			308	329	350	-12,0
263	500x190	62000	124000	1150	195	150	326	350	374	32,5
	630x236			910			331	355	379	12,5
	710x265			800			338	362	386	3,0

¹⁾ If the value is negative the brakedrum laps over the hub end for this amount.

Size	D _B x B [mm]	E ₀ [mm]	E [mm]	E ₁ [mm]	E ₂ [mm]	D ₁ [mm]	D ₂ [mm]	D ₃ [mm]	m *
67	200x75	3	14	23	32	111	67	80	9,6
87	200x75	3	14	20	26	141	87	103,5	13,2
	250x95		16	22	28				18,1
	315x118		18	24	30				28,3
106	250x95	3	16	30	44	171	106	129,5	24,3
	315x118		18	32	46				33,6
	400x150		20	34	48				52,0
130	315x118	5	20	32	44	210	130	156	45,3
	400x150		22	34	46				62,8
151	315x118	5	20	34	48	234	151	181	57,2
	400x150		22	36	50				74,5
178	400x150	6	23	40	57	274	178	209	93,8
	500x190		24	41	58				123,3
213	400x150	6	23	41	59	312	213	247	122,3
	500x190		24	42	60				151,8
	630x236		29	47	65				209,7
235	500x190	8	26	47	68	337	235	273	178,7
	630x236		31	52	73				236,3
	710x265		38	59	80				293,3
263	500x190	8	26	50	74	380	263	307	226,2
	630x236		31	55	79				283,3
	710x265		38	62	86				339,7

* m [kg]: up to size 151 weight for unbored coupling, from size 178 on weight for pilot bored coupling

The torques T_{Cnom} and T_{Cpeak} are valid for:

- Ambient temperatures of -20 °C to +65 °C.
- Operation within the range of the specified alignment values.

The max. permissible operating speed and the weight of the coupling depend on the length of the spacer.

For longer spacers, or circumferential speeds of more than 30 m/s, referred to the outer diameter of the coupling, we recommend to balance the coupling parts

6 Installation

6.1 To be observed prior to Installation



- **Danger of injuries!**
- **Disconnect the drive before carrying out any work on the coupling!**
- **Secure the drive against unintentional re-start and rotation!**
- **Incorrectly tightened bolts can cause serious personal injuries and property damages!**
- **If possible, assemble the coupling outside of the danger zone.**
- **Take care that suitable transportation means are at disposal and that the transportation ways are free of obstacles.**
- **In compliance with accident prevention regulations, you are obliged to protect all freely rotating parts by means of permanently installed guards against unintentional contact and falling down objects.**

The screw plugs of the sleeves partially have a diameter of 6 mm only!

- **As a minimum, the covers have to fulfil the requirements of protection type IP2X.**
 - **The covers have to be designed to prevent dust from depositing on the coupling.**
 - **The cover must not contact the coupling or impair the proper function of the coupling.**
 - **In order to avoid static charge, the coupling must not be mounted electrically insulated.**
 - **Provide for an equipotential bonding between input and output.**
- Take appropriate measures, such as sufficient ventilation of the operation site, good illumination, proper electrical tools etc. to ensure safety, before mounting or putting the coupling into operation and before carrying out any maintenance work.
 - Before starting to install the coupling, make sure that the necessary tools are at disposal:
 - to handle the parts
 - to join the interfaces
 - to align the coupling
 - to tighten the screw connections
 - When carrying out assembly or maintenance work on the coupling, always take care to avoid polluting the environment due to escaping lubricant.
 - Make sure that the speeds, torques and ambient temperatures as stated in chapter 5 'Technical Data' are not exceeded.
 - The maximum permissible bore diameters must not be exceeded.
 - Check whether the shaft-hub connections safely transmit the occurring operating torques.
 - The standard tolerance of TSCHAN for finish bores is fit H7.
 - Standard keyways comply with DIN 6885, sheet 1, fit P9.
 - Check the dimensions and tolerances of shafts, hub bores, keys and keyways.

6.2 Finish bore in a hub

The following procedure has to be observed to produce a finish bore in a hub:

- Clean and remove all preservatives from the hub.
- Mount the hub between the surfaces marked with \square and carefully align the hub according to the outer diameter $\varnothing D_2$.
- The values for $\varnothing d_{1max}$, $\varnothing d_{2max}$ listed in table 1 or table 2 are valid for keyed connections according to DIN 6885/1 and must not be exceeded.
- Select the bore fit so that an interference fit such as H7/m6 results when mating it with the shaft tolerance.
- Secure the hubs against axial movement on the shaft ends by using setscrews, shaft end plates or by means of a sufficient interference fit. A set screw must not be placed under the O-ring in the housing!
-

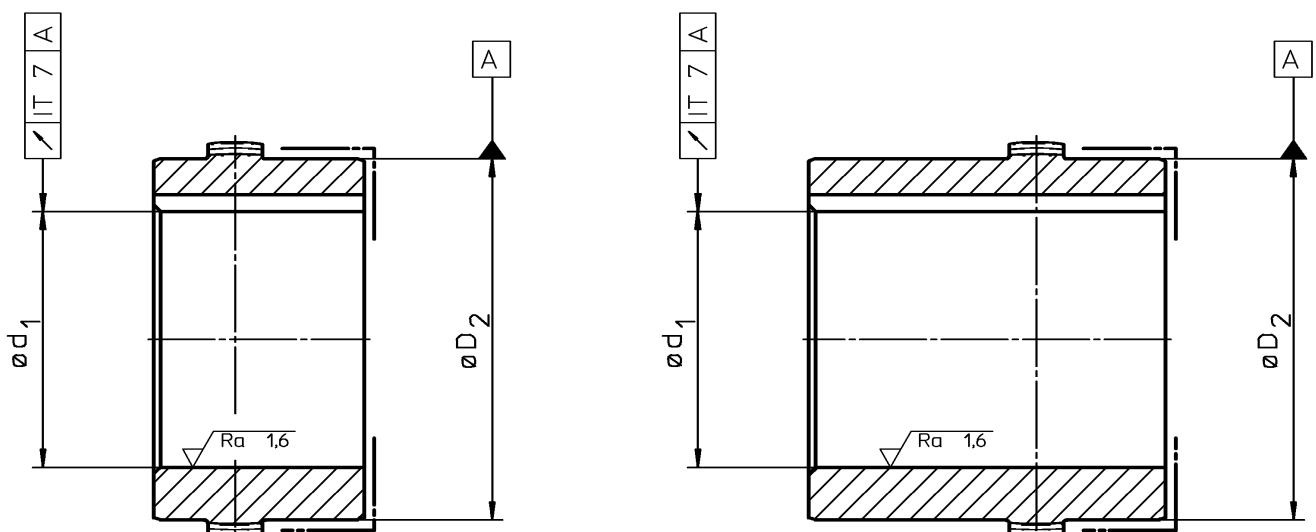

Consult TSCHAN GmbH in case of other shaft-hub connections.



- The stated maximum bore diameters are valid for keyed connections according to DIN 6885/1 and must not be exceeded.
- If these values are exceeded, the coupling can break.
- Flying coupling debris are a danger to life!

6.3 Coupling Installation

- Prior to installation, carefully clean the bores of the coupling hubs and the shaft ends. The surfaces must be clean, dry and free of grease.
- Remove the corrosion protection agent from the brake disk / drum
- Before aligning couplings with end float limitation, the zero position of the machine shaft (or the 'magnetic center' of the rotor in the case of electric motors) has to be determined first and marked on the machine that is not equipped with an axial bearing.
- Use suitable installation aids and hoists such as cranes or pulley blocks in the case of bigger couplings.
- Insert the slightly greased seals into the cleaned O-ring grooves in the housings (Fig. 4, pos. 1).
- Slide the housing halves in the correct direction over the free shaft ends (Fig. 4, pos. 2). For coupling **type ZEB** it is sufficient to push the housing covers with the inserted O-rings and the paper seals onto the shaft ends (fig. 5). Take care not to damage the seal rings.

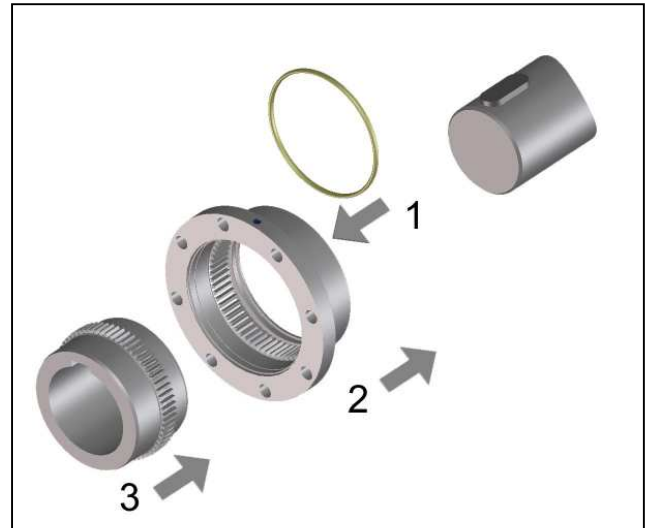

Fig. 4

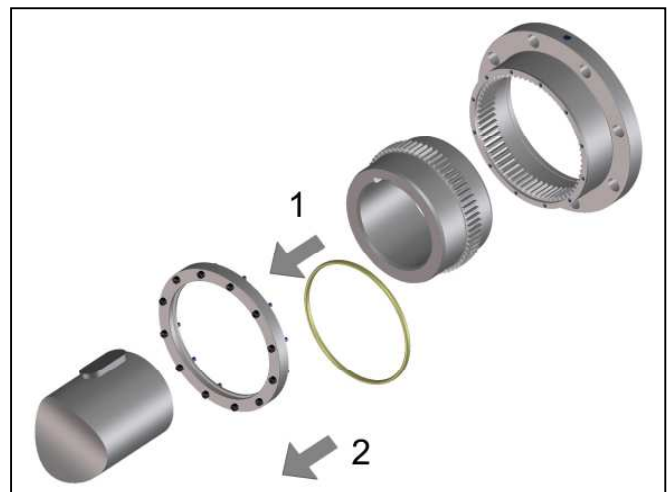

Fig. 5

Note:

To facilitate mounting, the hub can be uniformly heated to 80°C to 120°C.



- **Warning!**
- **Always wear heat-resistant gloves to protect yourself against injuries due to hot coupling components!**

- Push the coupling hubs onto the shaft ends as specified (Fig. 4, pos. 3 / Fig. 5, pos. 3). Make sure that the seal ring does not contact the heated hubs. **Pay attention to the asymmetrical gear teeth of the hubs!**
- Mount the hubs in such a manner that the shaft end is even with the inner bore opening (Fig. 6).
- Observe deviant agreements, which may exist!
- In case of doubt, please contact TSCHAN GmbH.
- When tightening possibly installed setscrews, secure them with an adhesive, such as e.g. Loctite 222, to prevent the screws from working loose and dropping out.
- Check the hub distance 'E' and adjust it according to table 1 or table 2 or acc. to an approved order-specific drawing. In case of doubt, please contact TSCHAN GmbH.
- Align the coupling according to the instructions given in chapter 7 'Coupling Alignment'.
- The threaded holes of setscrews have to be covered with an adhesive tape, so as to prevent damaging the O-rings while fitting them.
- Slight rub the housing teeth and hub teeth with a suitable lubricant according to table 8.
- Slide the housing halves over the hubs

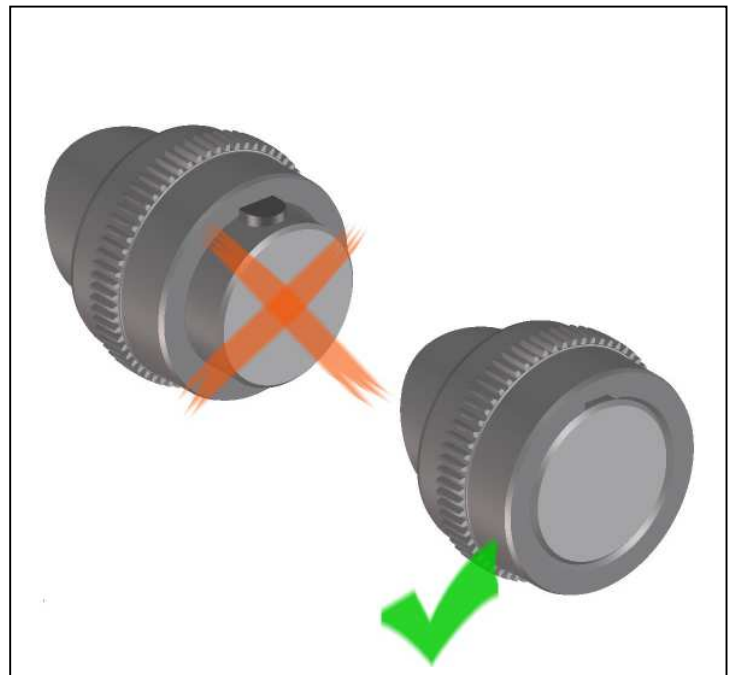

Fig. 6

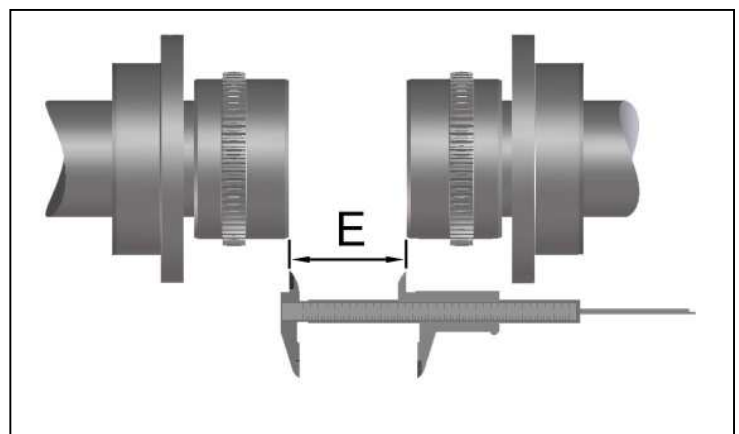

Fig. 7

- **Type ZEB:**
Insert the paper seal in between the O-ring cover and the housing and bolt down the cover to the housing. Properly tighten the cover bolts with the tightening torque stated in table 3.
- Insert the sealing compound in between the housing and spacer flanges. The contact faces on the flanges must be clean, dry and free from grease.
- Assemble the housings with the spacer. Make sure that the parts do not get canted at the centerings, and that the flange faces lie flat against each other..

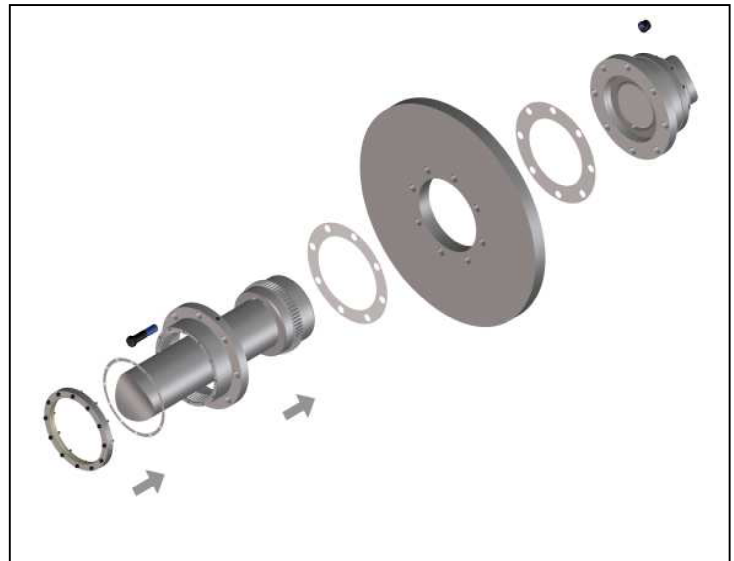

Fig. 8



- Use the fitted bolts and nuts as delivered. **The fastening means must not be cleaned or additionally lubricated!**
- Slightly tighten the nuts by hand.

- Exactly tighten the hexagon nuts to the tightening torque M_A according to table 4. Secure the fitted bolts against turning!
- It must be possible to easily move to-and-fro the coupling sleeve by the dimension E_0 of table 1 or Table 2, relative to the firmly mounted hub.

Table 3: Tightening torques for cover bolts

Size	67	87	106	130	151	178	213	235	263
T_{an} [Nm]	-	-	4	8	8	8	8	13	13
Thread M	-	-	4	5	5	5	5	6	6
Wrench size	-	-	3	4	4	4	4	5	5

Table 4: Tightening torques for hexagon nuts:

Size	67	87	106	130	151	178	213	235	263	286
M_A [Nm]	33,5	66	112	277	277	537	537	537	537	537
z x Thread M	6 x M8	8 x M10	6 x M12	6 x M16	8 x M16	8 x M20	8 x M20	10 x M20	10 x M20	14 x M20
Wrench size	10	12	14	19	19	24	24	24	24	24
Tool size	1/4"	3/8"	3/8"	1/2"	1/2"	1/2"	1/2"	1/2"	1/2"	1/2"

7 Coupling Alignment



- **Danger of injuries!**
- **Disconnect the drive before carrying out any work on the coupling.**
- **Secure the drive against unintentional re-start and rotating!**
- **Always make sure that the environment is not polluted by escaping lubricants while carrying out assembly and maintenance operations.**
- **Note:**
- **The precise alignment of the coupling increases its lifetime and reduces dangers when it is used.**
- **It is of utmost importance to observe the recommended alignment values. Exceeding the permissible misalignment values results in coupling damages and failures!**

Carefully align the shaft ends. The maximum permissible misalignment of the coupling depends on the operation speed.

Attention: Do not align to 'zero'. A slight offset is necessary in order to ensure the lubrication of the gear teeth.

When aligning the cold equipment take into account the expected thermal growth of the components, so that the permissible misalignment values for the coupling are not exceeded in operation

7.1 Axial Misalignment ΔK_a

- Adjust the distance E_0 , E_1 resp. E_2 between the hubs according to table 1 or table 2 (Fig. 9).
- In mounted state, it must be possible to move the coupling to-and-fro by the dimension E_0 relative to the firmly fitted hubs.

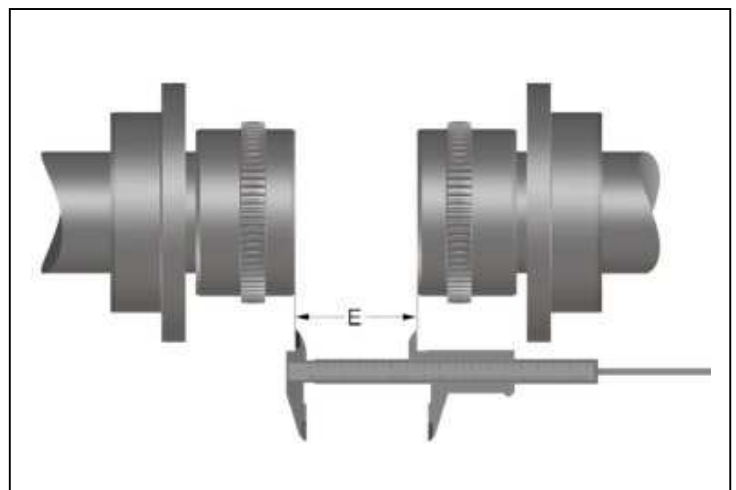

Fig. 9 hub distance E

7.2 Angular Misalignment ΔK_w

- Measure one complete revolution on the face of the outer diameter from one hub. To this purpose, turn the dial gauge by 360° . Determine the largest deviation ΔK_w (Fig. 10).

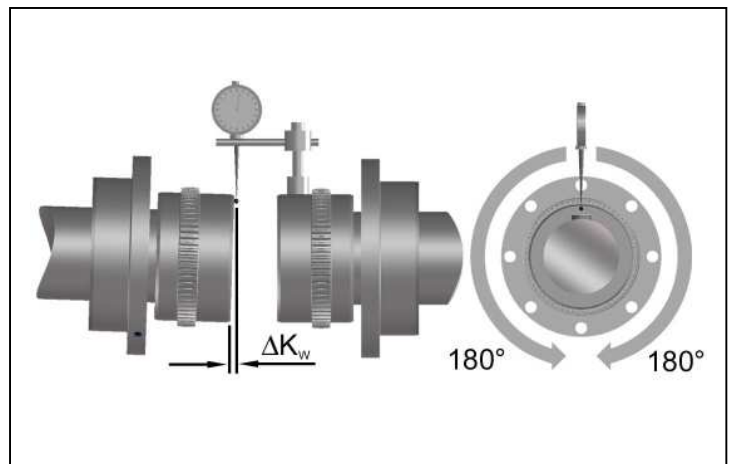

Fig. 10 Angular Misalignment ΔK_w messen

Table 5 Multiplier K_w Angular Misalignment:

Size	67	87	106	130	151	178	213	235	263
K_w	2,34	3,04	3,71	4,54	5,28	6,22	7,55	8,20	9,18

7.3 Radial Misalignment ΔK_r

- Measure one complete revolution. To this end, turn the dial gauge by 360° . Determine the largest deviation ΔK_r (Fig. 11).

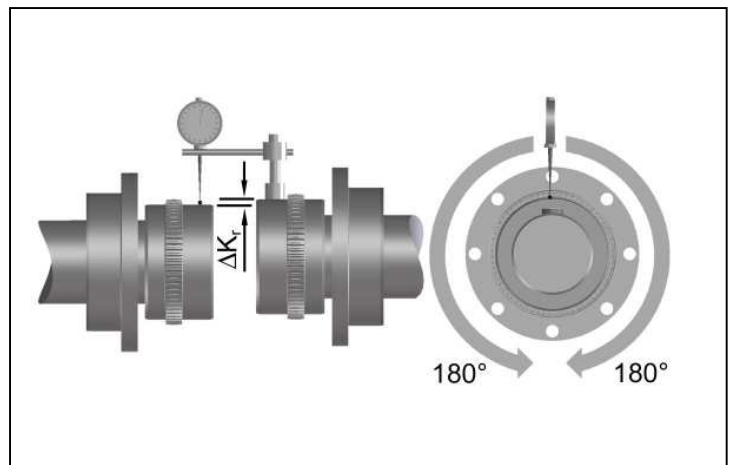

Fig. 11 Radial Misalignment ΔK_r measure

Table 6: Multiplier K_r Radial Misalignment:

Size	67	87	106	130	151	178	213	235	263
K_r	1,92	2,06	2,76	3,25	3,80	4,47	5,03	5,72	6,35

The combined angular and radial offset must correspond with the following formula:

$$0.1^\circ \leq \frac{\Delta K_w}{K_w} + \frac{\Delta K_r}{K_r} \leq 0.75 \cdot \Delta K_{wmax}$$

In case of deviations, the alignment must be corrected as necessary.

ΔK_{wmax} is dependent on the torque and the speed, and has to be determined according to diagram 1 in the POSIFLEX® catalog when selecting the coupling size.

8 Operation

When operating the coupling, its specific technical data have to be carefully observed (see chapter 5 'Technical Data'). These values must never be exceeded without the prior written approval by TSCHAN GmbH.

In order to ensure trouble-free and reliable performance of the coupling, the coupling has to be designed according to the selection specifications in the catalogue POSIFLEX® using a service factor that is appropriate to the operation conditions.

Any change in the service conditions or service parameters always necessitates the verification of the coupling design.

When putting the coupling into service, pay attention to the following:



- **Danger of injuries!**
- **Disconnect the drive before carrying out any work on the coupling!**
- **Secure the drive against unintentional re-start and rotation!**
- **Improperly tightened screws may cause parts to fly off and lead to most serious personal injuries and property damage!**
- **Before putting the coupling into operation, check the alignment and all screwed connections for correct tightening torque and firm fit!**
- **Before operating the coupling make sure that a sufficient quantity of a lubricant appropriate to the specific requirements of the coupling has been filled into the coupling.**
- **The coupling must be clean and tight.**
- **Before starting up the equipment, install all protective guards in order to avoid contact with freely moving or rotating parts.**
- **The covers have to comply with protection type IP2X as a minimum. The guard is to protect the surrounding area against flying objects (the screw plug has a diameter of 6 mm) and the coupling against falling objects.**
- **The guard shall be designed to prevent dust from depositing on the coupling parts.**
- **The guard must not contact the coupling, minimum distance 10 mm, nor impair its operation.**

When starting up and operating the coupling, pay attention to the following:

- Changes in operating noises
- Vibrations
- Leaks
- Other unusual phenomena

Attention!

- **Should you observe any unusual phenomena or problems when starting or operating the coupling, disconnect the driving equipment immediately!**
- Identify the cause for the problem using table 6 below "Operation Faults and Possible Causes" and correct the fault.
The listed problems are some examples to assist you in troubleshooting.
- **All the machinery components and operation modes have to be considered for the determination and correction of mechanical problems!**

Table 6 Operation Faults and Possible Causes:

Trouble	Cause	Risk Warning	Correction
Running noises/ vibrations	Alignment fault	Increased restoring forces on shafts and bearings of the connected machines.	<ul style="list-style-type: none"> - Disconnect drive - Check coupling components for damages and replace parts, if necessary - Check alignment - Check lubricant and quantity of lubricant
	Wrong lubricant or lack of lubricant	Higher reaction forces. Wear increases.	<ul style="list-style-type: none"> - Disconnect drive - Check coupling components for damages and replace parts, if necessary - Check alignment - Check correct type and quantity of lubricant, see chapter 9 'Maintenance'
	Worn out teeth	Higher reaction forces. Coupling fails.	<ul style="list-style-type: none"> - Disconnect drive - Check coupling components for damages and replace parts, if necessary - Check alignment - Check correct type and quantity of lubricant, see chapter 9 'Maintenance'
	Unbalance	Vibrations.	<ul style="list-style-type: none"> - Disconnect drive - Verify balance state of plant components and correct it, if necessary - Check O-rings and toothed parts for damages, and replace them, if necessary
Coupling teeth damages	Loose screw connections	Flying off screws, the spacer may fly out.	<ul style="list-style-type: none"> - Disconnect drive - Check coupling components for damages and replace parts, if necessary - Verify coupling alignment - Tighten the screws to the specified torque, and secure them against working loose, if necessary
	Alignment faults	Increased restoring forces on shafts and bearings of the connected machines.	<ul style="list-style-type: none"> - Disconnect drive - Remove cause for alignment fault - Replace coupling halves - Re-align coupling
	Overload due to very high torque	Tooth fracture! Coupling fails.	<ul style="list-style-type: none"> - Disconnect drive - Verify coupling design in cooperation with TSCHAN GmbH - Install larger coupling, if necessary - Replace coupling

Trouble	Cause	Risk Warning	Correction
	Wrong lubricant, lack of lubricant	Higher reaction forces and wear.	<ul style="list-style-type: none"> - Disconnect drive - Replace coupling halves - Verify coupling alignment - Use appropriate lubricant
	Torsional vibrations in the drive line	Tooth fracture!	<ul style="list-style-type: none"> - Disconnect drive - Analyze and eliminate cause for torsional vibrations - Check coupling components for damages and replace parts, if necessary - Verify coupling alignment

9 Maintenance

The torsionally stiff gear coupling POSIFLEX® has to be inspected and lubricated at regular intervals.

On the occasion of routine inspections or maintenance of the equipment, check:

- Lubricant quantity in the coupling
- tightness of the coupling
- alignment of coupling
- firm fit of all fastening elements
- remove dust deposits from coupling parts

9.1 Inspection and Maintenance



- **Danger of injuries!**
- **Disconnect the drive before carrying out any work on the coupling!**
- **Secure the drive against unintentional re-start and rotating!**
- **While carrying out assembly or maintenance operations on the coupling, avoid the pollution of the environment by lubricants that may escape.**

Check the alignment and tightness of the coupling after 4000 operation hours after the first start-up of the coupling, or after 12 months at latest. Check whether the coupling housing can be freely moved by the dimension E_0 relative to the hubs. Check that all the coupling parts are still in place. Fill up lubricant acc. to chapter 9.2. Make sure that the coupling is operating smoothly and without vibrations.

Every 8000 operation hours, however, at least every 2 years, the coupling must be opened in order to check the gear teeth and seals for damages or wear. Check the alignment, too. Before opening the coupling, mark the position of the hub relative to the sleeve. Upon completion of the inspection, re-assemble the geared parts in their original position. Make sure that the same teeth are in mesh. In doing so it is advisable to replace sealings, bolts and nuts.

Disconnect the drive immediately, if

- changes in operating noises
- vibrations
- leaks
- or other unusual phenomena occur while the coupling is operating

9.2 Lubrication



- **Danger of injuries!**
- **Disconnect the drive before carrying out any work on the coupling!**
- **Secure the drive against unintentional re-start and rotating!**

- Remove the screw plugs from both housing halves (Fig. 12).
- Bring the opposing filling openings in the horizontal line and fill in lubricant, e.g. by using a grease gun **in each coupling half**, until it comes out at the opposed bore (Fig. 12). See tables 8 and 9 regarding lubricant type and quantity.
- After having filled in lubricant, re-mount all the screw plugs and tighten them with the torque indicated in table 10.
- Only use such lubricants that are suitable for the particular requirements of the gear coupling.
- **Normal roller bearing grease is not suitable for use in gear couplings!**
- While working on the coupling make sure not to pollute the environment by lubricants that may escape.

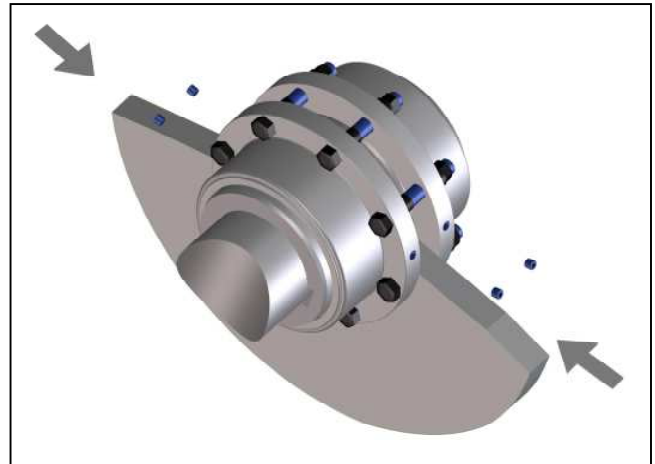

Fig. 12

Table 8: Recommended Lubricants

Normal speed and duty		High speed and heavy duty	
Producer	Brand	Producer	Brand
Agip	Agip GR MU/EP 1		
Caltex	Coupling grease	Caltex	Coupling grease
Castrol	Impervia MDX		
Chevron	Polyurea grease EP 0		
Esso	Fibrax 370		
Fina	Marson EPL 1 Lical EPL 1		
Gulf	Gulfcrown EP 0		
Klüber	Klüberplex GE 11-680 Grafloscon C-SG 500 Plus	Klüber	Klüberplex GE 11-680
Mobil	Mobilgrease XTC	Mobil	Mobilgrease XTC
Pennzoil	Multi-Purpose 705		
Shell	Alvania grease EP R-0 / EP 1	Shell	Albida GC1
Texaco	Coupling grease	Texaco	Coupling grease
Total	Specis EPG		

Table 9: Lubricant Quantity for complete coupling

Size	67	87	106	130	151	178	213	235	263
dm ³ ca.	0,05	0,07	0,13	0,21	0,36	0,52	0,80	0,98	1,5

Table 10: Tightening torques for screw plugs

Size	67	87	106	130	151	178	213	235	263
Tan [Nm]	7	10	10	10	10	10	10	10	10

Warning!



- Before putting the equipment into service, all safety guards must be installed to prevent unintentional contact with freely rotating parts.
- To avoid sparks, the covers for couplings used in explosive atmospheres should be made of stainless steel.
- The covers have to fulfil the requirements of protection type IP2X as a minimum.
- The covers have to be designed to prevent dust from depositing on the coupling parts.
- The cover must not touch the coupling and impair the proper operation of the coupling.

We do not assume any responsibility or warranty for any damages resulting from the use of accessories or spare parts, which have not originally been manufactured by TSCHAN GmbH.

10 Disposal

Disposal of the parts must be arranged in accordance with the regulations and laws of the country where the equipment is installed.